



# 16-TON PNEUMATIC TOGGLE PRESS



- COMPACT BENCHTOP
- ONE-SHOT LUBE SYSTEM
- LOW AIR CONSUMPTION
- VERY LOW MAINTENANCE
- ADAPTABLE

*CUSTOM PLATEN SIZES AVAILABLE*

### RAM FORCE

DISTANCE FROM BOTTOM OF STROKE	80 PSI	100 PSI
0.500	5557 lbs.	6946 lbs.
0.250	8128 lbs.	10,160 lbs.
0.125	11,686 lbs.	14,608 lbs.
.0625	16,650 lbs.	20,812 lbs.
.030	24,107 lbs.	30,134 lbs.
.020	29,568 lbs.	36,960 lbs.

### SPECIFICATIONS

<b>Stroke</b>	<b>1.5" -or- 2.0"(optional)</b>
<b>Shut Height</b>	<b>5.5 - 6.25"</b>
<b>Adjustment</b>	<b>+/- 0.375"</b>
<b>Throat Depth</b>	<b>5.375"</b>
<b>Air/Stroke</b>	<b>0.91 Cubic Feet @ 80 psi</b>
<b>Ram Size</b>	<b>1.5" Round with 13/16" bore</b>

## 16-Ton Benchtop Toggle Press

Contact Sales: 1-888-889-4287

# AIM JORACO

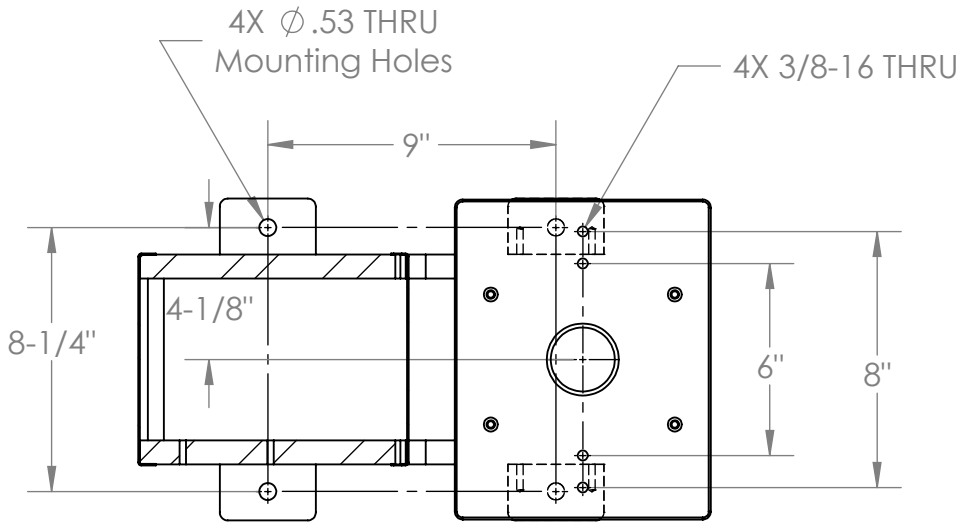

# MODEL TA3530

Frame Specifications

