



Model 2530 10-TON PNEUMATIC TOGGLE PRESS



Press above shown with OPTIONAL Lube,

- COMPLETE COMPATIBILITY
- ONE-SHOT LUBE SYSTEM
- LOW AIR CONSUMPTION
- VERY LOW MAINTENANCE
- REPLACEABLE BRONZE/PTFE BUSHINGS
- CONTROLLED SQUEEZE to OVER 20,000 lbs at 100 PSI

RAM FORCE		
DISTANCE FROM BOTTOM OF STROKE	80 PSI	100 PSI
0.500	3754 lbs.	4693 lbs.
0.250	5484 lbs.	6856 lbs.
0.125	7900 lbs.	9876 lbs.
0.0625	11,263 lbs.	14,079 lbs.
0.030	16,487 lbs.	20,609 lbs.
0.020	19,648 lbs.	24,560 lbs.

SPECIFICATIONS	
Stroke	1.5" -or- 2" (Optional)
Shut Height	4.5" to 5.25"
Adjustment	+/- 0.375"
Throat Depth	5.5"
Ram Size	1.375" Dia. with 13/16" bore

Dimensions for stroke, open height and throat depth can be customized upon request.

Automotive • Aerospace • Electronics • Medical • Industrial

Contact Us TODAY! 1-888-889-4287
www.Joraco.com sales@Joraco.com

AIM JORACO

4X \varnothing .53 THRU
Mounting Holes

4X 3/8-16 THRU

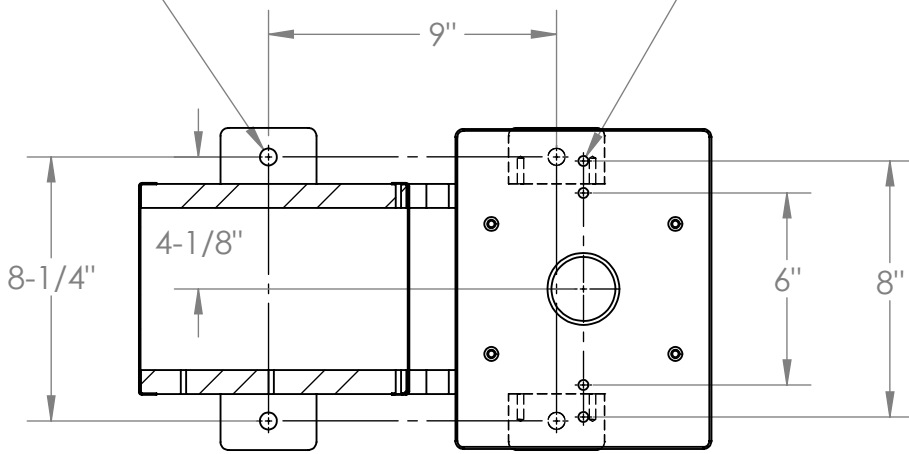

SECTION A-A

MODEL TA2530

Frame Specifications

